

Cravens Home Inspection Service L.L.C.

PO Box 925, Bixby, Oklahoma 74008

Office 918-369-6947

www.cravensinspections.com

Fax 918-369-6952

CLEAN AND SERVICE YOUR FURNACE

Most people don't think about their heating system until it's time to turn it on. If it doesn't work properly when you fire it up, you normally call for a service technician. As you can imagine, service technicians get busy at the beginning of the heating season.

WHAT ? Clean and service your furnace.

WHEN ? Furnaces should be cleaned and serviced every year. Beat the rush -- have it serviced now

WHY ? There are three good reasons to have your furnace serviced -- safety, better fuel efficiency, and longer furnace life.

HOW ? This is not a job you can do yourself. Contact a qualified contractor. Here's what they'll do for you:

- Test for carbon monoxide (CO).
- Check for debris in the exhaust flue. NOTE: This is not included in some furnace servicing.
- Clean the air filter.
- Check the operation of the thermostat and safety controls.
- Check the gas pilot safety system and clean as required or check the ignition system
- Clean the motor and fan.

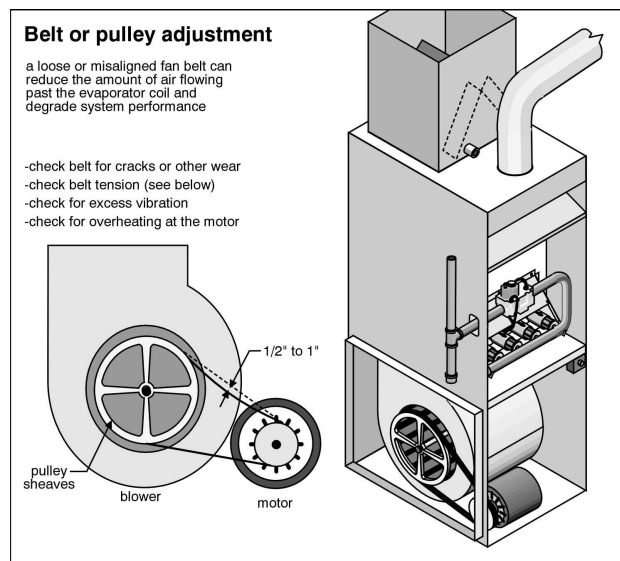

- Check the blower operation
- Check the condition, tension and alignment of the fan belt and adjust as necessary.
- Clean the burner(s) and set for proper ignition and combustion.

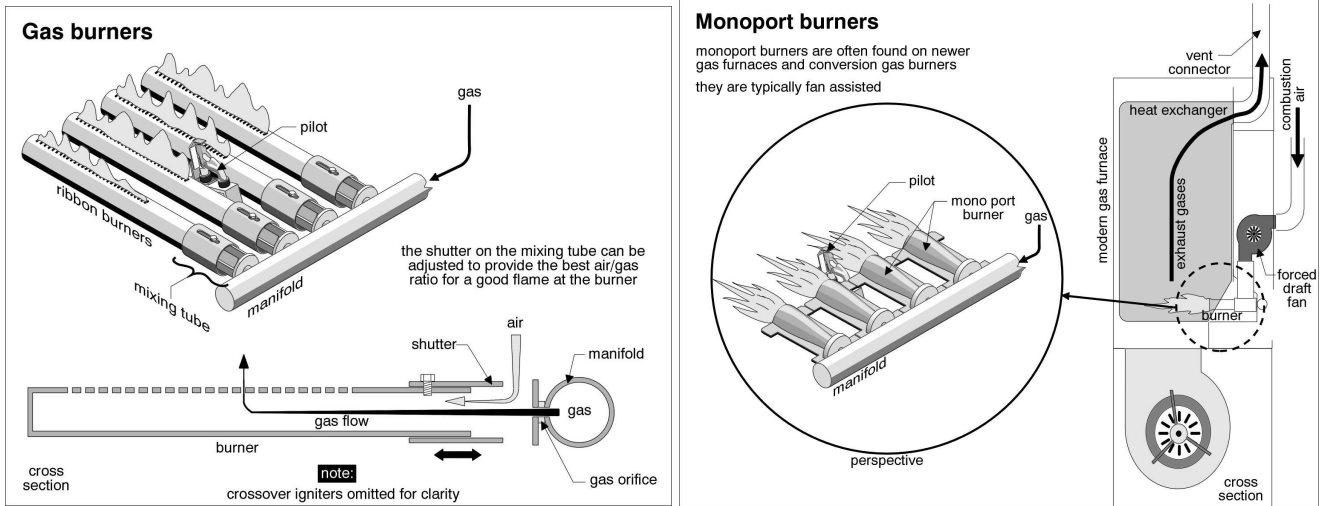

- Check the gas or oil piping to the furnace.

TIPS

The technician does not clean the humidifier as part of a normal cleaning and servicing contract. It is considered to be a user-serviceable component -- this means it's your job!

It's a good idea to clean it before the technician gets there, just in case you encounter a problem. If your humidifier starts leaking after you turn on the valve, you can ask the technician to repair it while the technician is in your home.

Find out if you have a maintenance contract on the furnace. The standard cleaning and service may be included. If this is the case, contact the heating contractor who has the service contract.

Charles Cravens
 Certified Home Inspector
 Oklahoma License #0073